

Inlet note: Use a sanitary tee with pipe extension to meet the NYSDOH requirement for baffle 16" below liquid level.

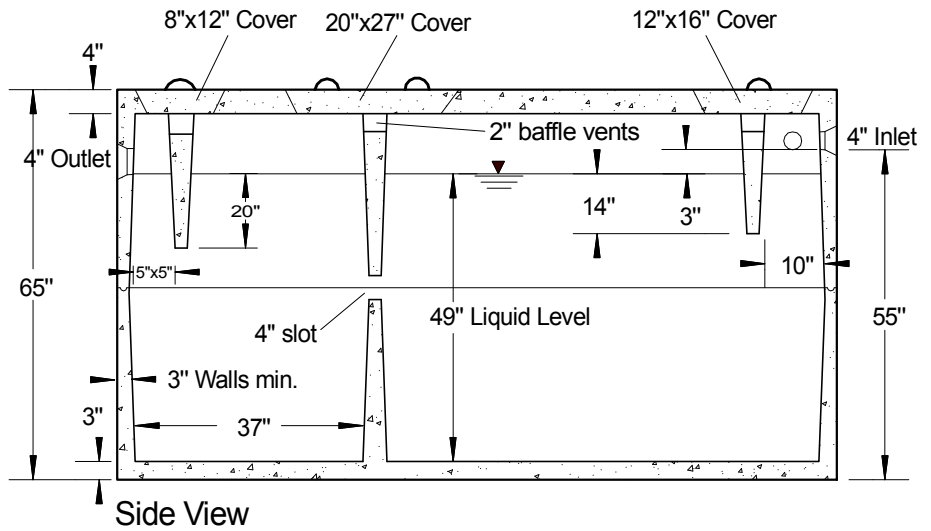

SPECIFICATIONS	
Concrete Min. Strength: 4,000 psi at 28 days Reinforcement: 6x6x10ga. WWM Air Entrainment: 6% Construction Joint: Butyl Rubber Sealant Pipe Connection: Polylok Seal (patented) Weight = 11,500 lbs Load Rating: 300 psf	<b>PRECAST SEPTIC TANKS</b> <b>MODEL ST-1500 / 1500 GALLONS</b>  <b>Woodard's Concrete Products, Inc.</b> 629 Lybolt Road, Bullville, NY 10915 (845) 361-3471 / Fax 361-1050  Page 4A 7/18/14